

General Advice

These instructions should be read in conjunction with the contract specification and drawings. They are intended to provide guidance in normal installation situations and are addressed to the installer on site. If there are any questions related to the design, unusual installation challenges, or any doubt, consult ABG for further advice. In all situations, responsibility for installation remains with the Installer.

Description

Claymat GCLs are used to provide a liquid and gas barriers in a wide range of environmental and civil engineering applications where containment barriers are required

Supply

Claymat GCLs are delivered in rolls typically 800–1300 kg. Roll dimensions and weights will vary with the dimensions of the product ordered. Each roll is wound around a core tube with 100 mm internal diameter. It is necessary to support this weight using an appropriate core pipe. For any installation, the core pipe must not deflect more than 75 mm, as measured from end to midpoint when a full **Claymat GCLs** roll is lifted.

Lifting chains or straps appropriately rated should be used in combination with a spreader bar made from an I-beam, as shown in

The spreader bar ensures that lifting chains or straps do not rub against the ends of the **Claymat GCLs** roll, allowing it to rotate freely during installation.

A front end loader, backhoe, dozer, or other equipment can be utilized with the spreader bar and core pipe or slings. Alternatively, a forklift with a “stinger” attachment may be used for on-site handling. A forklift without a stinger attachment should not be used to lift or handle the **Claymat GCLs** rolls. Stinger attachments (Figure 2) are specially fabricated to fit various forklift makes and models.

When installing over certain geosynthetic materials, a 4 wheel, all-terrain vehicle (ATV) can be used to deploy

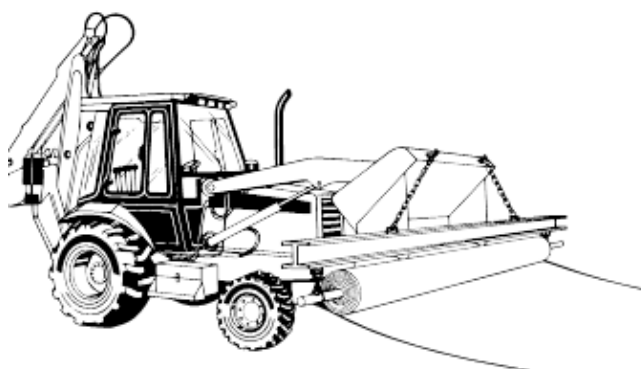

Fig. 1: Spreader Bar Assembly

the **Claymat GCLs**. An ATV can be driven directly on the **Claymat GCLs** provided that no sudden stops, starts, or turns are made.

Additional equipment needed for installation required

- Utility knife and spare blades (for cutting the **Claymat GCLs**)
- Granular bentonite for end-of-roll **Claymat GCLs** seams and for sealing around structures and details
- Waterproof tarpaulins (for temporary cover on installed material as well as for stockpiled rolls)
- Optional flat-bladed vise grips (for positioning the **Claymat GCLs** panel by hand)

Shipping, unloading and storage

1. All lot and roll numbers should be recorded and compared to the packing list. Each roll of **Claymat GCLs** should also be visually inspected during unloading to determine if any packaging has been damaged. Damage, whether obvious or suspected, should be recorded and the affected rolls marked.
2. Major damage suspected to have occurred during transit should be reported to the carrier and to **ABG** immediately. The nature of the damage should also be indicated on the bill of lading, with specific lot and roll numbers noted. Accumulation of some moisture within roll packaging is normal and does not damage the product.
3. The party directly responsible for unloading the **Claymat GCLs** should refer to this manual prior to shipment to ascertain the appropriateness of their unloading equipment and procedures. Unloading and on-site handling of the **Claymat GCLs** should be supervised.
4. **Claymat GCLs** can be delivered in either flatbed trucks, vans or curtain side trailers. There are three

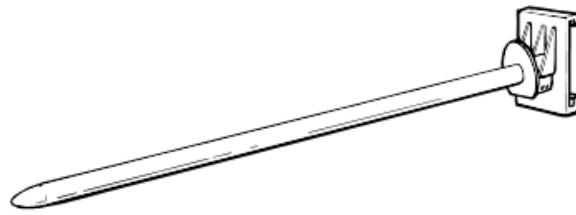

Fig. 2: Hook Mount Stinger Attachment

methods of unloading: core pipe and spreader bar, slings, or stinger bar.

5. To unload the rolls from the flat-bed using a core pipe and spreader bar, first insert the core pipe through the core tube. Secure the lifting chains or straps to each end of the core pipe and to the spreader bar mounted on the lifting equipment. Hoist the roll straight up and make sure its weight is evenly distributed so that it does not tilt or sway when lifted.
6. All **Claymat GCLs** are delivered with two polyester endless slings on each roll. If unloading with slings, check the position of the slings before lifting. Each sling should be tied off in the choke position, approximately one third (1/3) from the end of the roll. Hoist the roll straight up so that it does not tilt or sway when lifted.
7. In some cases, **Claymat GCLs** rolls will be stacked in three pyramids on flat-bed trucks. If slings are not used, rolls will require unloading with a stinger bar and extendible boom fork lift. Spreader bars will not work in this situation because of the limited access between the stacks of **Claymat GCLs**. To unload, guide the stinger through the core tube before lifting the **Claymat GCLs** roll and removing the truck.
8. An extendable boom fork lift with a stinger bar is required for un-loading vans. Rolls in the nose and centre of the van should first be carefully pulled toward the door using the slings provided on the rolls.
9. Rolls should be stored at the job site away from high traffic areas but sufficiently close to the active work

area to minimize handling. The designated storage area should be flat, dry, and stable. Moisture protection of the **Claymat GCL** is provided by its packaging; however, based on expected weather conditions, an additional tarpaulin or plastic sheet may be required for added protection during pro-longed outdoor storage.

10. Rolls should be stacked in a manner that prevents them from sliding or rolling. This can be accomplished by chocking the bottom layer of rolls. Rolls should be stacked no higher than the height at which they can be safely handled by laborers (typically no higher than four layers of rolls). Rolls should never be stacked on end.

Subgrade preparation

1. Subgrade surfaces consisting of coarse granular soils or gravels are not acceptable due to their large void fraction and puncture potential. Subgrade soils should range between fines and 25 mm, with no more than 25 percent larger than 12 mm. Larger particle sizes may be possible but a site-specific evaluation is needed to determine whether a cushion geotextile is required.

2. When the **Claymat GCL** is placed over an earthen subgrade, the subgrade surface must be prepared in accordance with the project specifications. The engineer's approval of the subgrade must be obtained prior to installation.

3. The finished surface should be firm and unyielding, without abrupt elevation changes, voids, cracks, ice, or standing water. The sub-grade surface must be smooth and free of vegetation, sharp-edged rocks, stones, sticks, construction debris, and other foreign mater that could contact the **Claymat GCLs**. The subgrade should be rolled with a smooth-drum compactor to remove any wheel ruts greater than 25mm in depth, footprints, or other abrupt grade changes. Furthermore, all protrusions extending more than 12 mm from the subgrade surface shall be removed, crushed, or pushed into the surface with a smooth-drum compactor.

4. **Claymat GCL** may be installed on a frozen subgrade, but the subgrade soil in the unfrozen state should meet the above requirements.

Installation

1. **Claymat GCL** rolls should be taken to the work area of the site in their origi-nal packaging. The orientation of the **Claymat GCL** (i.e., which side faces up) may be important if the **Claymat GCL** has two different types of geosynthetics. Check with the project engineer to determine if there is a preferred installation orientation for the **Claymat GCL**. If no specific orientation is required, allow the roll to unwind from the bottom (Figure 3) rather than pulling from the top (Figure 4). For pond applications ABG recommends to install **Claymat GCL** with laminated geomembrane facing up. Therefore it will be necessary to rewind material on job site for



Fig. 3: "Natural" orientation

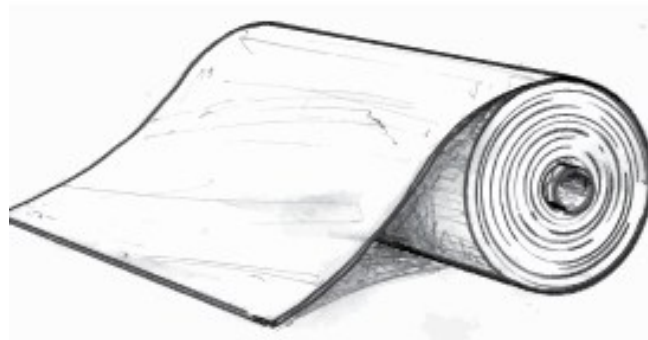

Fig. 4: Top of the roll

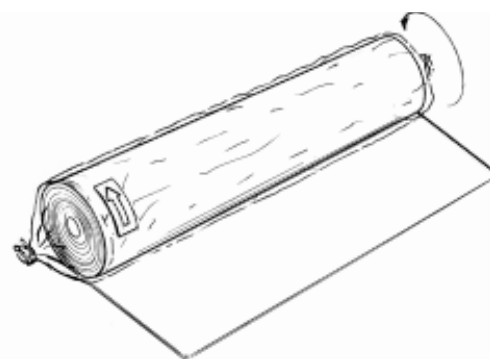

Fig. 5: Direction to unroll Claymat GCL on ground

products with thick weldable geomembrane 1mm and for product with non-welded geomembrane 0,5mm. Prior to deployment, the packaging should be carefully removed without damaging the **Claymat GCL**

2. Equipment which could damage the **Claymat GCL** should not be allowed to travel directly on it. Therefore, acceptable installation may be accomplished whereby the **Claymat GCL** is unrolled in front of backwards-moving equipment (Figure 6). If the installation equipment causes rutting of the subgrade, the subgrade must be restored to its originally accepted condition before placement continues.

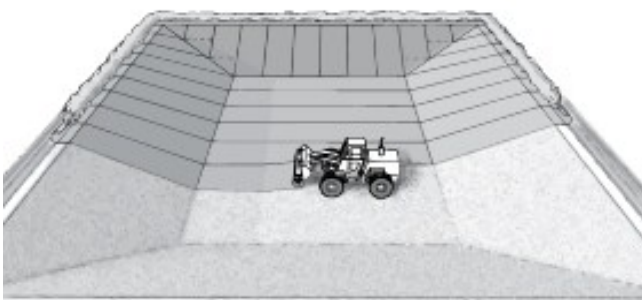

Fig. 6: Typical CETCO installation technique

3. If sufficient access is available, **Claymat GCL** may be deployed by suspending the roll at the top of the slope, with a group of laborers pulling the material off of the roll, and down the slope (Figure 7).

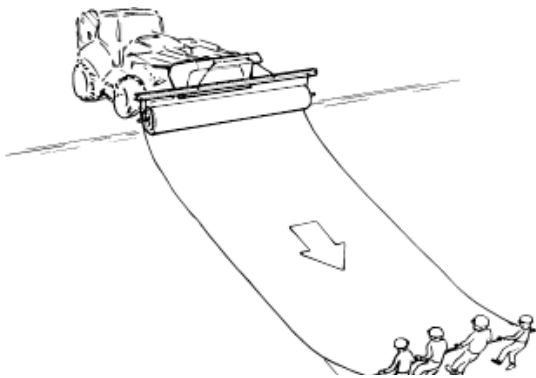

Fig. 7: Unrolling Claymat GCL

4. **Claymat GCL** rolls should not be released on the slope and allowed to unroll freely by gravity.

5. Care must be taken to minimize the extent to which the **Claymat GCL** is dragged across the subgrade to avoid damage to the bottom surface of the **Claymat GCL**. Care must also be taken when adjusting **Claymat CLT** panels to avoid damage to the geotextile surface of one panel of GCL by the textured sheet of another panel of

Claymat GCL. A temporary geosynthetic subgrade cover commonly known as a slip sheet or rub sheet may be used to reduce friction damage during placement.

6. The **Claymat GCL** should be placed so that seams are parallel to the direction of the slope.

7. End-of-panel seams should also be located at least 3 ft from the toe and crest of slopes steeper than 4H:1V. End-of-roll seams on slopes should be used only if the liner is not expected to be in tension.

8. All **Claymat GCL** panels should lie flat, with no wrinkles or folds, especially at the exposed edges of the panels.

9. The **Claymat GCL** should not be installed in standing water or during rainy weather. Only as much **Claymat GCL** shall be deployed as can be covered at the end of the working day with soil, geomembrane, or a temporary waterproof tarpaulin. The **Claymat GCL** shall not be left uncovered overnight. If the **Claymat GCL** is hydrated when no confining stress is present, it may be necessary to remove and replace the hydrated material. **ABG** recommends that premature hydration be evaluated on a case-by-case basis. The project engineer, CQA inspector, and **ABG technical department** should be consulted for specific guidance if premature hydration occurs. The type of **Claymat GCL**, duration of exposure, degree of hydration, location in the liner system, and expected bearing loads should all be considered. In many instances, a needlepunch reinforced **Claymat GCL** may not require removal/replacement if the following are true:

- The geotextiles have not been separated, torn, or otherwise damaged
- There is no evidence that the needle punching between the two geotextiles has been compromised
- The **Claymat GCL** does not leave deep indentations when stepped upon
- Overlapped seams with **Claymat CLT** enhancement are intact

Anchorage

1. If required by the project drawings, the end of the **Claymat GCL** roll should be placed in an anchor trench at the top of a slope. The front edge of the trench should be rounded to eliminate any sharp corners that could cause excessive stress on the **Claymat GCL**. Loose soil should be re-moved or compacted into the floor of the trench.

2. If a trench is used for anchoring the end of the **Claymat GCL**, soil backfill should be placed in the trench to provide resistance against pull-out. The size and shape of the trench, as well as the appropriate backfill procedures should be in accordance with the project drawings and specifications. Typical dimensions are shown in [Figure 8](#).

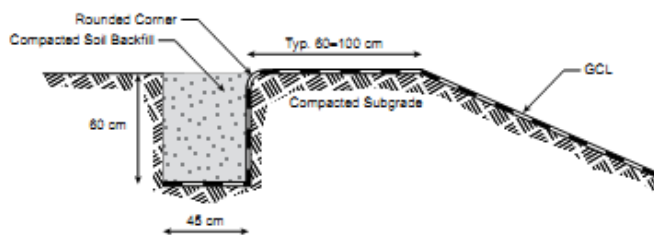

Fig. 8: Typical anchor trench design

3. The **Claymat GCL** should be placed in the anchor trench such that it covers the entire trench floor but does not extend up the rear trench wall.

4. Sufficient anchorage may alternately be obtained by extending the end of the **Claymat GCL** roll back from the crest of the slope, and placing cover soil. The length of this “runout” anchor should be prepared in accordance with project drawings and specifications.

5. **Claymat GCLs** may be terminated in a single anchor trench together with other geosynthetics provided that none of the geosynthetics are expected to be in tension.

Seaming

1. GCL seams are constructed by overlapping adjacent panel edges and ends. Care should be taken to ensure that the overlap zone is not contaminated with loose soil or other debris.

2. Longitudinal seams should be overlapped a minimum of 15 cm for **ABG** geosynthetic clay liners. For high-head applications (greater than 30 cm) involving **Claymat CL** or **CLT** a minimum longitudinal seam overlap of 30 cm is recommended.

3. **Claymat GCL** can be manufactured with impregnated edges providing self-seaming capabilities in their longitudinal overlaps, and therefore may not require supplemental bentonite. If impregnated edges are not present longitudinal bentonite enhanced seams are required. They are constructed by overlapping the adjacent panels a minimum 15 cm, exposing the underlying edge, and applying a continuous bead of granular bentonite approximately 7,5 cm from the edge.

4. End-of-panel overlapped seams should be overlapped 60 cm for **Claymat GCL**.

5. End-of-panel overlapped seams are constructed such that they are shingled in the direction of the grade to prevent runoff from entering the overlap zone. End-of-panel seams on slopes are permissible, provided adequate slope stability analysis has been conducted (i.e., the **Claymat GCL** is not expected to be in tension). Bentonite-enhanced seams are required for all **Claymat GCL** end-of-panel overlapped seams.

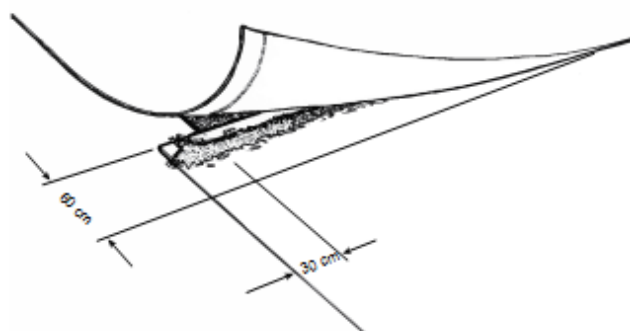

Fig. 9: End-of-panel overlapped seam

6. End-of-panel, bentonite-enhanced, overlapped seams are constructed first by overlapping the adjacent panels, exposing the underlying panel, and then applying a continuous bead or fillet of granular sodium bentonite 30 cm from the edge of the underlying panel (Figure 9). The minimum application rate at which the bentonite is applied is 0,4 kg/m.

exposing the underlying edge, and applying a continuous bead of granular bentonite approximately 15 cm from the edge. The minimum application rate for the granular bentonite is 0.4 kg/m. **Claymat CL or CLT** products with non-welded geomembrane have longitudinal margins without glue allowing for proper seam execution. In some cases, the geomembrane overlaps can be executed with **Claymat CL seamtape** additionally.

7. For pond applications involving **Claymat CTL** and with non-welded geomembrane, longitudinal seams are constructed by overlapping adjacent panels by 30 cm, layering **Claymat GCL** core to **Claymat GCL** core and membrane to membrane, in accordance with Figure 10,

8. End-of-panel, **Claymat CL or CLT** with non-welded geomembranes, bentonite-enhanced, overlapped seams are constructed first by overlapping the adjacent panels, exposing the underlying panel, and then applying a continuous bead or fillet of granular bentonite 30 cm from the edge of the underlying panel between the two **Claymat GCL** cores (Figure 11). The minimum application rate at which the bentonite is applied is 0.4 kg/m. The

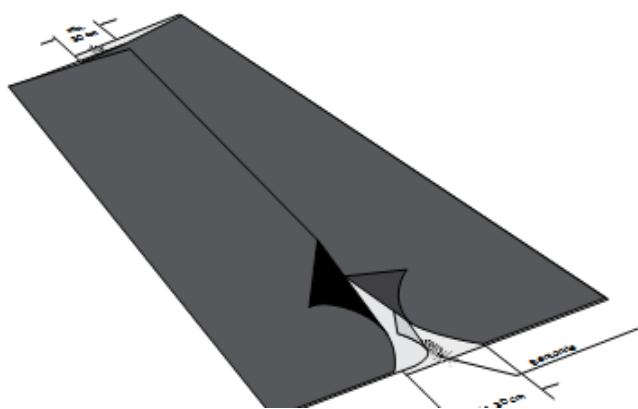

Fig. 10A: Longitudinal regular seams

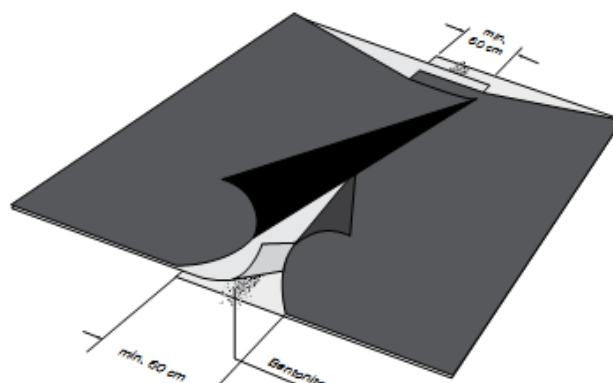

Fig. 11A: End-of-panel regular seams

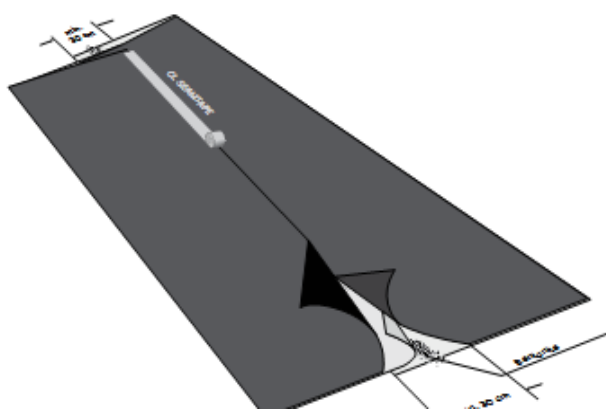

Fig. 10B: Longitudinal seams with Claymat CL seamtape

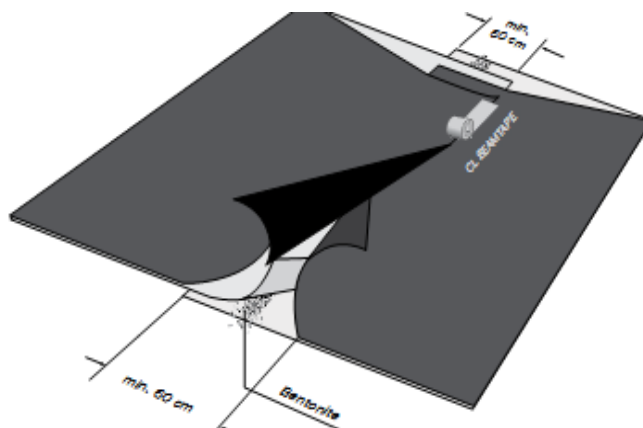

Fig. 11B: End-of-panel seams with Claymat CL seamtape

bottom membrane panel covers the top **Claymat GCL** panel, and the top membrane panel covers the bottom membrane panel in accordance with [Figure 11](#). **Claymat CL or CLT** products with non-welded geomembrane does not have end-of-panel margins without glue. Therefore it is advisable to peel off geomembrane in order to provide proper seam execution. In some cases, the geomembrane overlaps can be executed with **Claymat CL seamtape** additionally.

9. **Claymat CL seamtape** is 12 cm wide single sided high-tack butyl lap tape suitable for joining and sealing overlap seams of geomembrane. All surfaces for installing of **Claymat CL seamtape** should be clean, dry and free from frost, grease and loose materials. Apply direct from the reel and install continuous line of **Claymat CL seamtape** centered on the membrane overlap with adhesive side against the membrane. Press firmly to adhere tape to membrane surface. Cut tape as required to install. Overlap all connecting tape ends a minimum 50 mm to form a continuous seal. Application temperature range: +5°C to +40°C

10. For applications where **Claymat CL or CLT** with a thick membrane has been specified **ABG** recommends welding the seams for a higher factor of safety against leakage. The minimum thickness of geomembrane which can be welded is 1.0mm. GBR-Cs with weldable geomembranes have longitudinal and end-of-panel margins which are not glued allowing for simple seam execution. The seams should be executed as per [Figure 10B&11B](#) but with geomembrane welding instead of using tape.

11. **ABG** recommends welding the overlaps using the hot wedge method, with a dual seam consisting of two parallel welded zones and unwelded air space between them. The dual seam should be produced using self-propelled wedge welding equipment with gauges for monitoring the welding temperature. Machine speed and welding temperature should be adjusted to prevailing conditions. The seams should be formed by a competent installer with experience in this type of work.

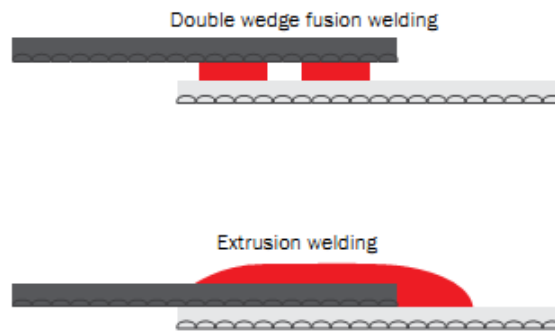

Fig. 7: Double wedge fusion welding and extrusion welding

12. All surfaces for welding should be clean, dry and properly prepared, a clean, dry cloth can be used for this purpose. Welding apparatus should be inserted at one end of the seam area. After clamping down the pressure rollers and engaging the wedge, the drive motor can be turned on. Any interruption of the seaming process should be minimised and where unavoidable clearly marked and appropriately fixed.

13. After the dual seam is executed, the continuity and water tightness of the seams should be checked using a standard non-destructive test with air pressure within the channel between dual seams, under a supervisor's observation. For additional guidance, refer to ASTM D5820 (Standard Practice for Pressurized Air Channel Evaluation of Dual Seamed Geomembranes). Double wedge fusion welding Extrusion welding

14. The extrusion welding method is recommended for patching. This technique involves extruding molten resin at the edge of two geomembrane panels, and provides a homogeneous bond. Apparatus for this kind of welding should be equipped with gauges for monitoring the temperature of the extrusion. The temperature and flow rate should be adjusted to ambient conditions.

15. For extrusion welding, the geomembrane should be overlapped by a minimum of 7.5cm. The welding area should be prepared using sanding or grinding, without causing any damage to the geomembrane. The installer should determine if preheating is necessary. The extrusion welds must not be cooled by water or any other means. Prior to starting a new seaming sequence,

the extruder should be cleaned of all cooled and degraded debris.

16. Seams welded by extrusion should be checked using a standard non-destructive test with vacuum chamber under a supervisor's observation. For additional guidance, refer to ASTM D5641 (Standard Practice for Geomembrane Seam Evaluation by Vacuum Chamber).

17. In cases where two dual seams cross, the cross dual seam should be cut back to the edge of the weld seam, and extrusion welding should be applied 10 cm in all directions from the "meeting" point of the two dual seams to create a "T".

Sealing around penetrations and structures

1. Cutting the **Claymat GCL** should be performed using a sharp utility knife. Frequent blade changes are recommended to avoid irregular tearing of the geotextile components of the **Claymat GCL** during the cutting process.

2. The **Claymat GCL** should be sealed around penetrations and structures embedded in the subgrade in accordance with Figures 13 through 16. Granular bentonite shall be used liberally (min. 0,4 kg/m) to seal the **Claymat GCL** to these structures.

3. When the **Claymat GCL** is placed over a horizontal pipe penetration, a "notch" should be excavated into the subgrade around the penetration (Figures 13 & 14). The notch should then be backfilled with either granular

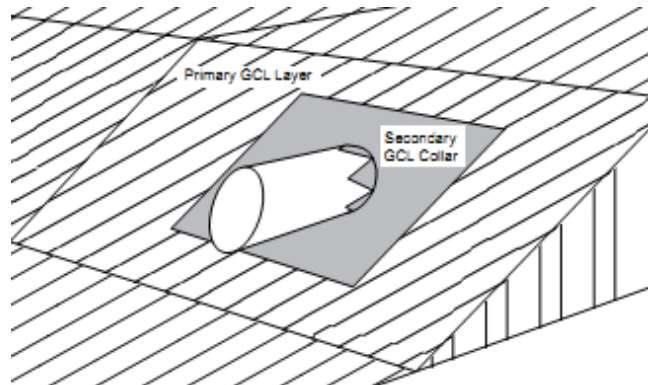

Fig. 14: Isometric view of a completed horizontal pipe penetration

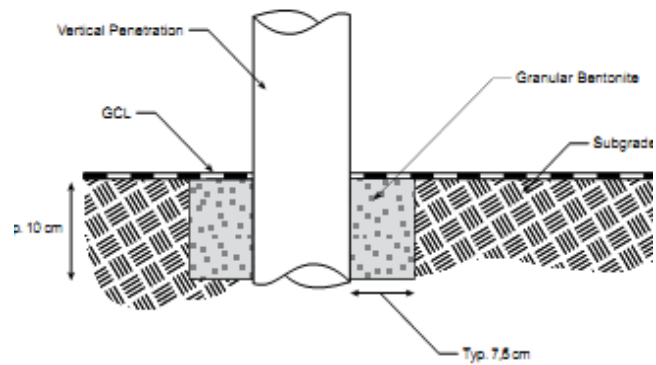

Fig. 15: Cross-section of a vertical penetration

bentonite or bentonite paste. A secondary collar of **Claymat GCL** should be placed around the penetration. It is helpful to first trace an outline of the penetration on the **Claymat GCL** and then cut a "star" pattern in the collar to enhance the collar's fit to the penetration. Granular bentonite should be applied between the primary **Claymat GCL** layer and the secondary **Claymat GCL** collar.

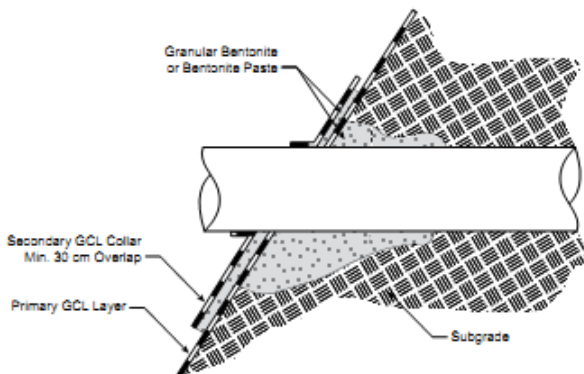

Fig. 13: Cross-Section of a horizontal pipe penetration

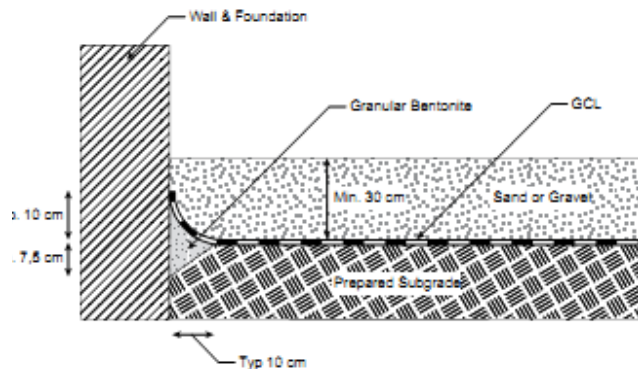

Fig. 16: Cross-section of Claymat GCL seal against an embedded

4. Vertical penetrations are prepared by notching into the subgrade as shown in Figure 15. A secondary collar can be placed as shown in Figure 13 & 14.

5. When the **Claymat GCL** is terminated at a structure or wall that is embedded into the subgrade on the floor of the containment area, the subgrade should be notched. The notch is filled with granular bentonite; the **Claymat GCL** should be placed over the notch and up against the structure (Figure 16). Connection to the structure can be accomplished by placement of soil or stone backfill in this area. When structures or walls are at the top of a slope, additional detailing may be required. Contact **ABG** for specific guidance.

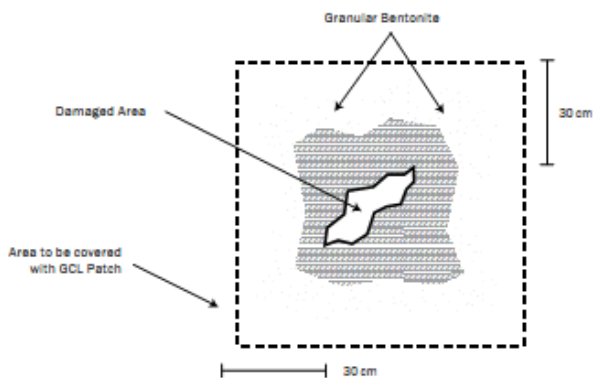

Fig. 17: Damage Repair by patching

Damage Repair

1. If the **Claymat GCL** is damaged (torn, punctured, perforated, etc.) during installation, it may be possible to repair it by cutting a patch to fit over the damaged area (Figure 17). The patch should be cut to size such that a minimum overlap of 30 cm is achieved around all parts of the damaged area. Granular bentonite should be applied around the damaged area prior to placement of the patch. It may be necessary to use an adhesive such as wood glue to affix the patch in place so that it is not displaced during cover placement. Smaller patches may be tucked under the damaged area to prevent patch movement

Cover Placement

1. The final thickness of soil cover on the **Claymat GCL** varies with the application. A minimum cover layer must be at least 30 cm thick to provide confining stress of at least 5 kPa to the **Claymat GCL**, eliminate the potential for seam separation and prevent damage by equipment,

erosion, etc. For ponds application, in some cases, **ABG** recommends to increase the thickness of cover soil to min. 50cm.

2. Cover soils should be free of angular stones or other foreign matter that could damage the **Claymat GCL**. Cover soils should be approved by the engineer with respect to particle size, uniformity, and chemical compatibility. Consult **ABG** if cover soils have high concentrations of calcium (e.g. limestone, dolomite, gypsum, seashell fragments).

3. Recommended cover soils should have a particle size distribution ranging between fines and 25 mm, unless a cushioning geotextile is specified.

4. Soil cover shall be placed over the **Claymat GCL** using construction equipment that minimizes stresses on the **Claymat GCL**. A minimum thickness of 30 cm of cover soil should be maintained between the equipment tires/tracks and the **Claymat GCL** at all times during the covering process. In high-traffic areas such as on roadways, a minimum thickness of 60 cm is required.

5. Soil cover should be placed in a manner that prevents the soil from entering the **Claymat GCL** overlap zones. Soil cover should be pushed up on slopes, not down slopes, to minimize tensile forces on the **Claymat GCL**.

6. When a textured geomembrane is installed over the **Claymat GCL**, a temporary geosynthetic covering known as a slip sheet or rub sheet should be used to minimize friction during placement and to allow the textured geomembranes to be more easily moved into its final position.

7. Cyclical wetting and drying of **Claymat GCL** covered only with geomembrane can cause overlap separation. Soil cover should be placed promptly whenever possible. Geomembranes should be covered with a white geotextile and/or operations layer without delay to minimise the intensity of wet-dry cycling. If there is the potential for unconfined cyclic wetting and drying over an extended period of time, the longitudinal seam

overlaps should be increased based on the project engineer's recommendation.

8. To avoid seam separation, the **Claymat GCL** should not be put in excessive tension by the weight or movement of textured geomembrane on steep slopes. If there is the potential for unconfined geomembrane expansion and contraction over an extended period of time, the longitudinal seam overlaps should be increased based upon the project engineer's recommendation.

Hydration

1. Hydration is usually accomplished by absorption of moisture from soil. However, in cases where the containment of non-aqueous liquid is required, it may be necessary to hydrate the covered **Claymat GCL** with water prior to use.

2. If manual hydration is necessary, water can be introduced by flooding the covered lined area or using a sprinkler system. If flooding, care must be taken to diffuse the energy of the water discharge so that the cover material is not displaced.

3. If the GCL is hydrated when no confining stress is present, it may be necessary to remove and replace the hydrated material. **ABG** recommends that premature hydration be evaluated on a case-by-case basis.

Terms and Conditions

Site specific engineering design should be carried out after site investigation has provided all the necessary information.

The assessment of suitable safety factors in relation to each particular project must always remain the responsibility of the design engineer.